

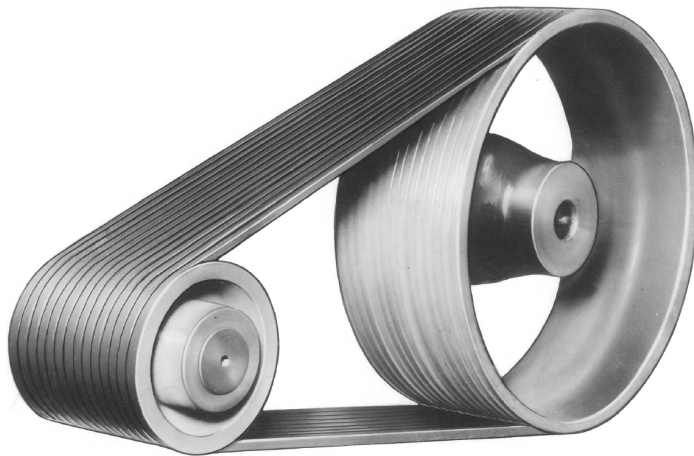

SUPER WEDGE DRIVES



3V, 5V, AND 8V CROSS SECTIONS SPECIAL MADE-TO-ORDER SHEAVES USE WITH FUL-GRIP (QD) BUSHINGS

The Maurey Super Wedge Sheave makes full use of the most advanced developments in modern high strength metals, including ductile iron, and of modern foundry and machining techniques. They reduce drive weight by 25% and more. Their narrower grooves and small diameters save vital inches of space with no sacrifice in capacity to carry horsepower load. In their smoothly machined grooves, belts are perfectly seated and protected from abrasions. Balanced overall construction makes for smooth true running drives. However, please note that cast iron sheaves cannot exceed 6500 feet per minute rim speed. Also, special or dynamic balancing should be considered when rim speeds exceed 5000 feet per minute.

Full Size Range

Super Wedge Sheaves are available from stock in a complete range of sizes in 3V, 5V and 8V

3V Sheaves are available in 1-groove through 10-groove construction

5V Sheaves are available in 2-groove through 10-groove construction

8V Sheaves are available in 4-groove through 12-groove construction

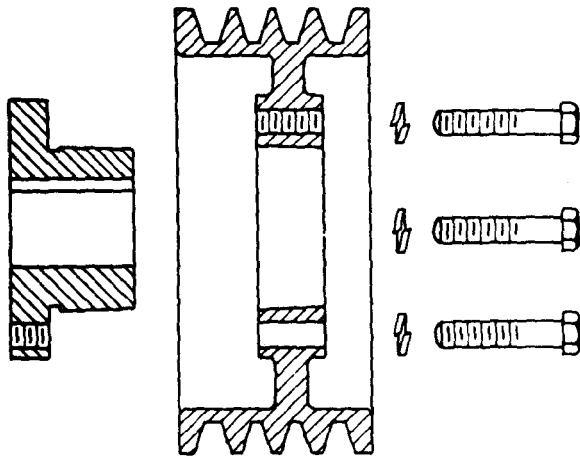

STANDARD MOUNTING ASSEMBLY
Fig. 1

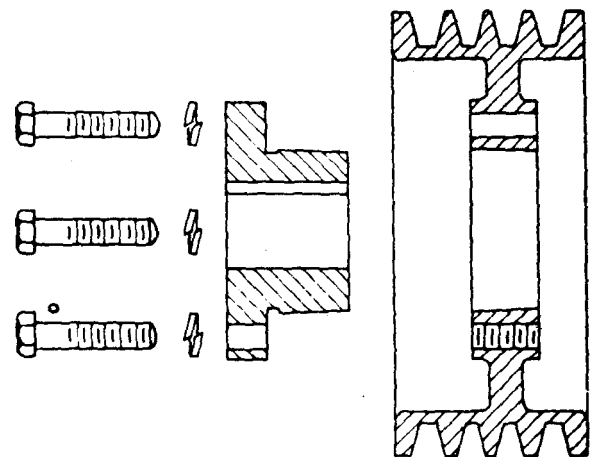

REVERSE MOUNTING ASSEMBLY
Fig. 2

INSTALLATION AND REMOVAL OF SHEAVES

INSTALLATION

1. Make sure the bore of the sheave and the tapered cone surface of the bushing are free of all the foreign substances such as paint, dirt, lubricants, etc. Do not use lubricants on installation.
2. Assemble bushings and sheave as shown above in Figures 1 and 2, whichever applies. With cap screws loosely inserted, the bushing remains fully expanded to assume a sliding fit on the shaft. Note: When installing bushings M thru S, locate the extra holes in the hub as far as possible from the bushing's saw cut in order to reduce the possibility of bushing flange breakage. CAUTION: Do not use lubricants on screw threads or tapered surfaces
3. With key on shaft, slide sheave assembly to its desired position with cap screw heads on outside. (Exception: Some shaft lengths may require the sheaves to be reversed with the cap screw heads to the inside - see Figure 2.)
4. Line up the sheave assembly and tighten cap screws evenly and progressively to the torque value listed in the table. Never allow the sheave to be drawn in contact with the bushing flange. There should be a gap of 1/8" to 1/4" between the sheave hub and the bushing flange. If the gap is closed, the shaft is seriously undersize.
5. Tighten the set screw to hold the key securely on the shaft during operation.

CAUTION: When mounting a "FUL-GRIP" bushing, the tightening force of the screws is multiplied many times by the wedging action of the tapered surface. This action compresses the bushing for a snug fit on the shaft. If extreme screw tightening force or lubricants are applied in mounting the "FUL-GRIP" bushing, bursting pressures will be created in the hub of the mounted sheave which may cause it to crack.

Refer to the recommended torque ratings

REMOVAL

1. Loosen and remove cap screws.
2. Insert cap screws in tapered removal holes and starting with bolt farthest from sawnut on bushing, tighten evenly and progressively until sheave is loose on bushing. If sheaves in Figure 2 are installed with cap screw heads next to motor, loosen cap screws and use a wedge between the bushing and the sheave.
3. Remove sheave and bushing

CAUTION: Excessive or unequal pressure on the jack screws can break the bushing flange

Bushing	Wrench Torque (In.-Lbs)	Wrench Length (Inches)	Wrench Pull (Pounds)
JA	60	4	15
SH	108	4	27
SDS	108	4	27
SDS	108	4	27
SK	180	6	30
SF	360	6	60
E	720	12	60
F	900	12	75
J	1620	12	135
M	2700	15	180
N	3600	15	240
P	5400	18	300
W	7200	24	300
S	9000	30	300

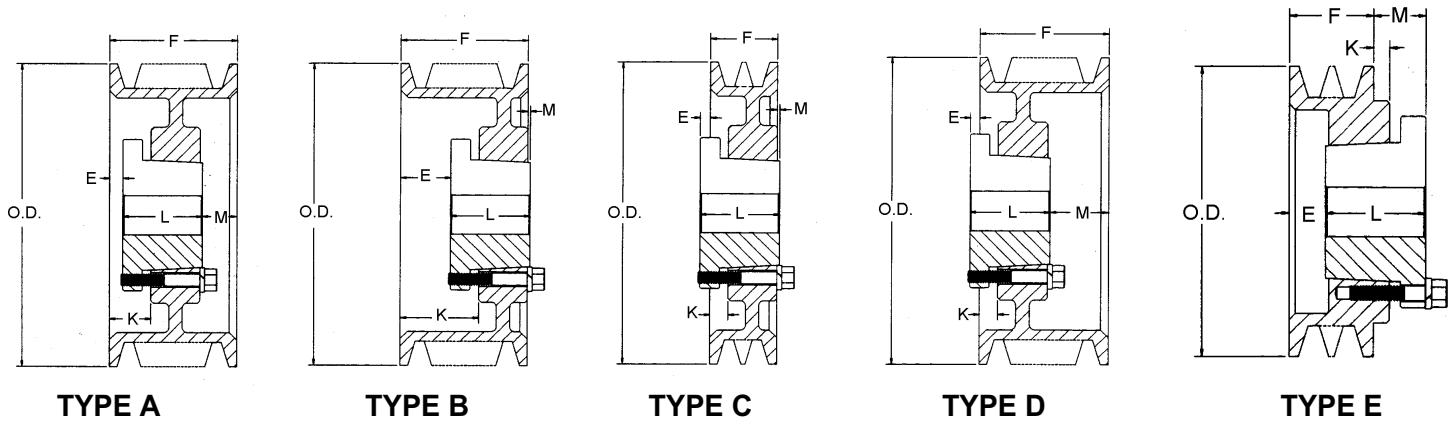

Part Number Explanation

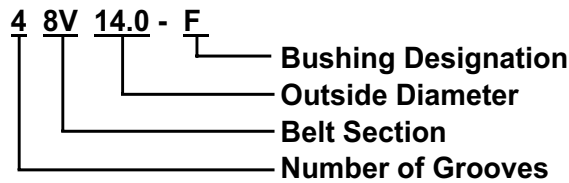

Figure Following Letter in Column Headed "TYPE" in Table Below Indicates Sheave Construction
1 - Solid, No Web. 2 - Web. 3 - Arms

O.D.	PART NUMBER	LIST**	4 GROOVE							PART NUMBER	LIST**	5 GROOVE						
			F = 4-7/8									F = 6						
			BUSH	TYPE	E	K	L	M	WT			BUSH	TYPE	E	K	L	M	WT
12.5	48V12.5	\$ 544.00	F	A1	1/8	1-3/16	3-5/8	1-1/8	85.5	58V12.5	\$ 588.00	F	A1	1-1/4	2-5/16	3-5/8	1-1/8	93.3
13.2	48V13.2	\$ 552.00	F	A2	1/8	1-3/16	3-5/8	1-1/8	78.4	58V13.2	\$ 618.00	F	A2	1-1/4	2-5/16	3-5/8	1-1/8	88.2
14.0	48V14.0	\$ 560.00	F	A2	1/8	1-3/16	3-5/8	1-1/8	84.5	58V14.0	\$ 660.00	F	A2	1-1/4	2-5/16	3-5/8	1-1/8	95.2
15.0	48V15.0	\$ 596.00	F	A2	1/8	1-3/16	3-5/8	1-1/8	92.6	58V15.0	\$ 700.00	F	A2	1-1/4	2-5/16	3-5/8	1-1/8	104.7
16.0	48V16.0	\$ 660.00	F	A2	1/8	1-3/16	3-5/8	1-1/8	98.8	58V16.0	\$ 740.00	F	A2	1-1/4	2-5/16	3-5/8	1-1/8	112.1
17.0	48V17.0	\$ 720.00	F	A2	1/8	1-3/16	3-5/8	1-1/8	109.4	58V17.0	\$ 846.00	J	A2	3/4	2	4-1/2	3/4	141.0
18.0	48V18.0	\$ 760.00	F	A2	1/8	1-3/16	3-5/8	1-1/8	118.1	58V18.0	\$ 900.00	J	A2	3/4	2	4-1/2	3/4	157.0
19.0	48V19.0	\$ 790.00	F	A2	1/8	1-3/16	3-5/8	1-1/8	128.3	58V19.0	\$ 960.00	J	A2	3/4	2	4-1/2	3/4	169.0
20.0	48V20.0	\$ 820.00	J	A3	3/16	1-7/16	4-1/2	3/16	128.3	58V20.0	\$ 990.00	J	A2	3/4	2	4-1/2	3/4	167.5
21.2	48V21.2	\$ 840.00	J	A3	3/16	1-7/16	4-1/2	3/16	142.8	58V21.2	\$1,150.00	J	A2	3/4	2	4-1/2	3/4	183.8
22.4	48V22.4	\$ 886.00	J	A3	3/16	1-7/16	4-1/2	3/16	154.2	58V22.4	\$1,310.00	M	B2	15/32	1-15/16	6-3/4	1-7/32	276.3
24.8	48V24.8	\$1,190.00	M	C3	21/32	13/16	6-3/4	1-7/32	247.5	58V24.8	\$1,390.00	M	B3	15/32	1-15/16	6-3/4	1-7/32	266.5
30.0	48V30.0	\$1,350.00	M	C3	21/32	13/16	6-3/4	1-7/32	286.7	58V30.0	\$1,570.00	M	B3	15/32	1-15/16	6-3/4	1-7/32	327.6
35.5	48V35.5	\$1,790.00	M	C3	21/32	13/16	6-3/4	1-7/32	342.0	58V35.5	\$1,990.00	M	B3	15/32	1-15/16	6-3/4	1-7/32	404.0
40.0	48V40.0	\$1,970.00	M	C3	21/32	13/16	6-3/4	1-7/32	407.6	58V40.0	\$2,240.00	M	B3	15/32	1-15/16	6-3/4	1-7/32	441.0
44.5	48V44.5	\$2,590.00	M	C3	21/32	13/16	6-3/4	1-7/32	461.0	58V44.5	\$2,990.00	N	C3	3/4	15/16	8-1/8	1-3/8	580.5
53.0	48V53.0	\$3,240.00	M	C3	21/32	13/16	6-3/4	1-7/32	557.0	58V53.0	\$3,480.00	N	C3	3/4	15/16	8-1/8	1-3/8	688.0

NOTE: Weight includes bushing with average bore size.

** List Prices Shown are for Sheave Only. Refer to Page 15 for Bushing List Price and Dimensions.

All Dimensions in Inches

8V stock sheave dimensions super wedge sheave drives

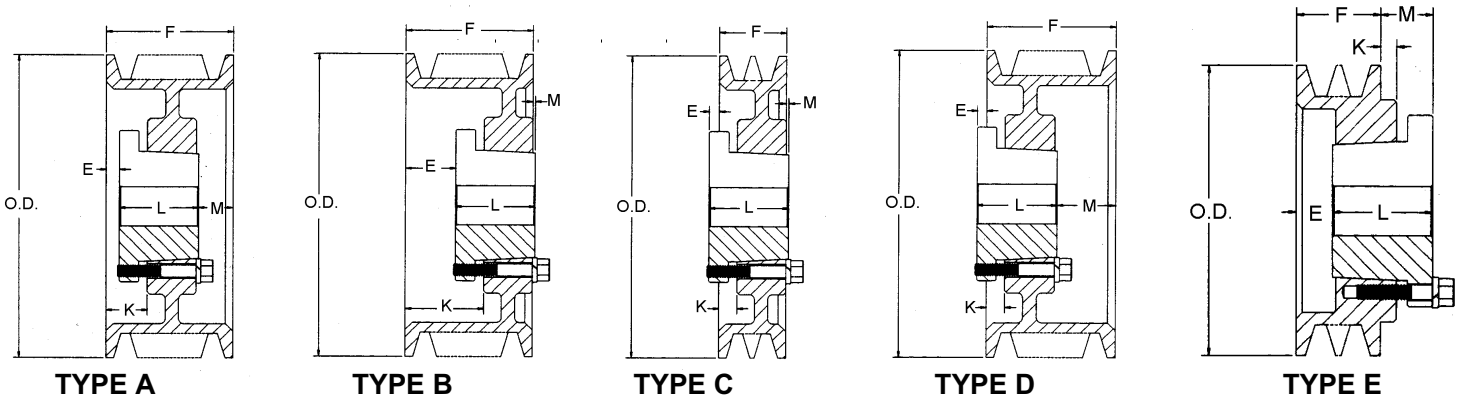

Figure Following Letter in Column Headed "TYPE" in Table Below Indicates Sheave Construction
1 - Solid, No Web. 2 - Web. 3 - Arms

O.D.	PART NUMBER	LIST** PRICE	6 GROOVE							PART NUMBER	LIST** PRICE	8 GROOVE						
			F = 7-1/8									F = 9-3/8						
			BUSH	TYPE	E	K	L	M	WT			BUSH	TYPE	E	K	L	M	WT
12.5	68V12.5	\$ 618.00	F	A1	1-1/4	2-5/16	3-5/8	2-1/4	100.9	88V12.5	\$ 780.00	J	A1	2-5/16	3-9/16	4-1/2	2-9/16	129.1
13.2	68V13.2	\$ 660.00	F	A2	1-1/4	2-5/16	3-5/8	2-1/4	96.6	88V13.2	\$ 824.00	J	A1	2-5/16	3-9/16	4-1/2	2-9/16	144.5
14.0	68V14.0	\$ 722.00	F	A2	1-1/4	2-5/16	3-5/8	2-1/4	104.1	88V14.0	\$ 866.00	J	A2	2-5/16	3-9/16	4-1/2	2-9/16	136.6
15.0	68V15.0	\$ 774.00	J	A2	1-5/16	2-9/16	4-1/2	1-5/16	127.2	88V15.0	\$ 928.00	J	A2	2-5/16	3-9/16	4-1/2	2-9/16	146.5
16.0	68V16.0	\$ 824.00	J	A2	1-5/16	2-9/16	4-1/2	1-5/16	143.5	88V16.0	\$ 1,010.00	J	A2	2-5/16	3-9/16	4-1/2	2-9/16	164.5
17.0	68V17.0	\$ 928.00	J	A2	1-5/16	2-9/16	4-1/2	1-5/16	153.0	88V17.0	\$ 1,124.00	M	A2	2-15/32	3-15/16	6-3/4	5/32	244.1
18.0	68V18.0	\$ 1,000.00	A2	1-5/16	2-9/16	4-1/2	1-5/16	169.0	88V18.0	\$ 1,200.00	M	A2	2-15/32	3-15/16	6-3/4	5/32	257.0	
19.0	68V19.0	\$ 1,040.00	J	A2	1-5/16	2-9/16	4-1/2	1-5/16	182.0	88V19.0	\$ 1,240.00	M	A2	2-15/32	3-15/16	6-3/4	5/32	280.0
20.0	68V20.0	\$ 1,190.00	M	B2	1-15/32	2-15/16	6-3/4	1-3/32	242.8	88V20.0	\$ 1,280.00	M	A2	2-15/32	3-15/16	6-3/4	5/32	292.6
21.2	68V21.2	\$ 1,320.00	M	B2	1-15/32	2-15/16	6-3/4	1-3/32	263.3	88V21.2	\$ 1,380.00	M	A2	2-15/32	3-15/16	6-3/4	5/32	314.0
22.4	68V22.4	\$ 1,560.00	M	B2	1-15/32	2-15/16	6-3/4	1-3/32	280.9	88V22.4	\$ 1,590.00	M	A2	2-15/32	3-15/16	6-3/4	5/32	345.7
24.8	68V24.8	\$ 1,590.00	M	B3	15/32	1-15/16	6-3/4	3/32	285.5	88V24.8	\$ 1,790.00	N	A3	9/16	2-1/4	8-1/8	11/16	423.7
30.0	68V30.0	\$ 1,610.00	M	B3	15/32	1-15/16	6-3/4	3/32	354.4	88V30.0	\$ 1,840.00	N	A3	9/16	2-1/4	8-1/8	11/16	468.9
35.5	68V35.5	\$ 2,190.00	N	C3	9/16	1-1/8	8-1/8	7/16	537.0	88V35.5	\$ 2,390.00	N	A3	9/16	2-1/4	8-1/8	11/16	588.0
40.0	68V40.0	\$ 2,440.00	N	C3	9/16	1-1/8	8-1/8	7/16	549.9	88V40.0	\$ 2,640.00	N	A3	9/16	2-1/4	8-1/8	11/16	663.0
44.5	68V44.5	\$ 3,390.00	N	C3	9/16	1-1/8	8-1/8	7/16	619.5	88V44.5	\$ 3,790.00	P	B3	3/4	2-5/8	9-3/8	3/4	860.0
53.0	68V53.0	\$ 3,720.00	N	C3	9/16	1-1/8	8-1/8	7/16	768.0	88V53.0	\$ 3,960.00	P	B3	3/4	2-5/8	9-3/8	3/4	992.0
63.0	68V63.0	\$ 6,190.00	P	B3	1/8	2	9-3/8	2-3/8	1027.0	88V63.0	\$ 6,990.00	P	B3	3/4	2-5/8	9-3/8	3/4	1262.0
71.0	68V71.0	\$ 9,000.00	P	B3	1/8	2	9-3/8	2-3/8	1200.0	88V71.0	\$ 10,000.00	W	B3	0	2-1/4	11-3/8	2	1725.0

O.D.	PART NUMBER	LIST** PRICE	10 GROOVE							PART NUMBER	LIST** PRICE	12 GROOVE						
			F = 11-5/8									F = 13-7/8						
			BUSH	TYPE	E	K	L	M	WT			BUSH	TYPE	E	K	L	M	WT
12.5	108V12.5	\$ 948.00	J	A1	2-5/16	3-9/16	4-1/4	4-13/16	148.9	128V12.5	\$ 2,080.00	M	A1	2-15/32	3-15/16	6-3/4	4-21/32	198.0
13.2	108V13.2	\$ 1,114.00	J	A2	2-5/16	3-9/16	4-1/2	4-13/16	148.6	128V13.2	\$ 2,120.00	M	A1	2-15/32	3-15/16	6-3/4	4-21/32	225.0
14.0	108V14.0	\$ 1,278.00	J	A2	2-5/16	3-9/16	4-1/2	4-13/16	161.0	128V14.0	\$ 2,160.00	M	A1	2-15/32	3-15/16	6-3/4	4-21/32	245.8
15.0	108V15.0	\$ 1,442.00	M	A1	2-15/32	3-15/16	6-3/4	2-13/32	264.0	128V15.0	\$ 2,200.00	M	A1	2-15/32	3-15/16	6-3/4	4-21/32	285.5
16.0	108V16.0	\$ 1,608.00	M	A2	2-15/32	3-15/16	6-3/4	2-13/32	296.7	128V16.0	\$ 2,240.00	M	A1	2-15/32	3-15/16	6-3/4	4-21/32	324.0
17.0	108V17.0	\$ 1,648.00	M	A2	2-15/32	3-15/16	6-3/4	2-13/32	269.1	128V17.0	\$ 2,280.00	M	A2	2-15/32	3-15/16	6-3/4	4-21/32	324.0
18.0	108V18.0	\$ 1,720.00	M	A2	2-15/32	3-15/16	6-3/4	2-13/32	295.0	128V18.0	\$ 2,320.00	M	A2	2-15/32	3-15/16	6-3/4	4-21/32	338.0
19.0	108V19.0	\$ 1,760.00	M	A2	2-15/32	3-15/16	6-3/4	2-13/32	318.0	128V19.0	\$ 2,400.00	N	A2	9/16	2-1/4	8-1/8	5-3/16	412.0
20.0	108V20.0	\$ 1,860.00	M	A2	2-15/32	3-15/16	6-3/4	2-13/32	318.6	128V20.0	\$ 2,480.00	N	A2	9/16	2-1/4	8-1/8	5-3/16	411.0
21.2	108V21.2	\$ 2,040.00	M	A2	2-15/32	3-15/16	6-3/4	2-13/32	340.7	128V21.2	\$ 2,560.00	N	A2	9/16	2-1/4	8-1/8	5-3/16	421.0
22.4	108V22.4	\$ 2,246.00	N	A2	9/16	2-1/4	8-1/8	2-15/16	411.1	128V22.4	\$ 2,640.00	N	A2	9/16	2-1/4	8-1/8	5-3/16	478.0
24.8	108V24.8	\$ 2,290.00	N	A2	9/16	2-1/4	8-1/8	2-15/16	463.0	128V24.8	\$ 3,000.00	N	A2	9/16	2-1/4	8-1/8	5-3/16	516.5
30.0	108V30.0	\$ 2,350.00	N	A3	9/16	2-1/4	8-1/8	2-15/16	557.5	128V30.0	\$ 3,380.00	P	A3	3/4	2-5/8	9-3/8	3-3/4	672.1
35.5	108V35.5	\$ 2,790.00	P	A3	3/4	2-5/8	9-3/8	1-1/2	727.0	128V35.5	\$ 3,660.00	P	A3	3/4	2-5/8	9-3/8	3-3/4	837.0
40.0	108V40.0	\$ 3,140.00	P	A3	3/4	2-5/8	9-3/8	1-1/2	817.9	128V40.0	\$ 3,960.00	P	A3	3/4	2-5/8	9-3/8	3-3/4	909.5
44.5	108V44.5	\$ 4,190.00	P	A3	3/4	2-5/8	9-3/8	1-1/2	927.0	128V44.5	\$ 4,880.00	P	A3	3/4	2-5/8	9-3/8	3-3/4	1097.0
53.0	108V53.0	\$ 5,000.00	P	A3	3/4	2-5/8	9-3/8	1-1/2	1137.0	128V53.0	\$ 8,000.00	W	A3	5/8	2-7/8	11-3/8	1-7/8	1482.0
63.0	108V63.0	\$ 9,000.00	W	B3	3/8	2-5/8	11-3/8	1/8	1652.0	128V63.0	\$ 10,000.00	W	A3	5/8	2-7/8	11-3/8	1-7/8	1777.0
71.0	108V71.0	\$ 11,500.00	W	B3	3/8	2-5/8	11-3/8	1/8	1865.0	128V71.0	\$ 13,000.00	W	A3	5/8	2-7/8	11-3/8	1-7/8	2180.0

NOTE: Weight includes bushing with average bore size. See page 15 for bushing dimensions.
** List Prices Shown are for Sheave Only. Refer to Page 15 for Bushing List Price and Dimensions.

All Dimensions in Inches